

4L60/65/70E

PUMP & INPUT SHAFT USAGE

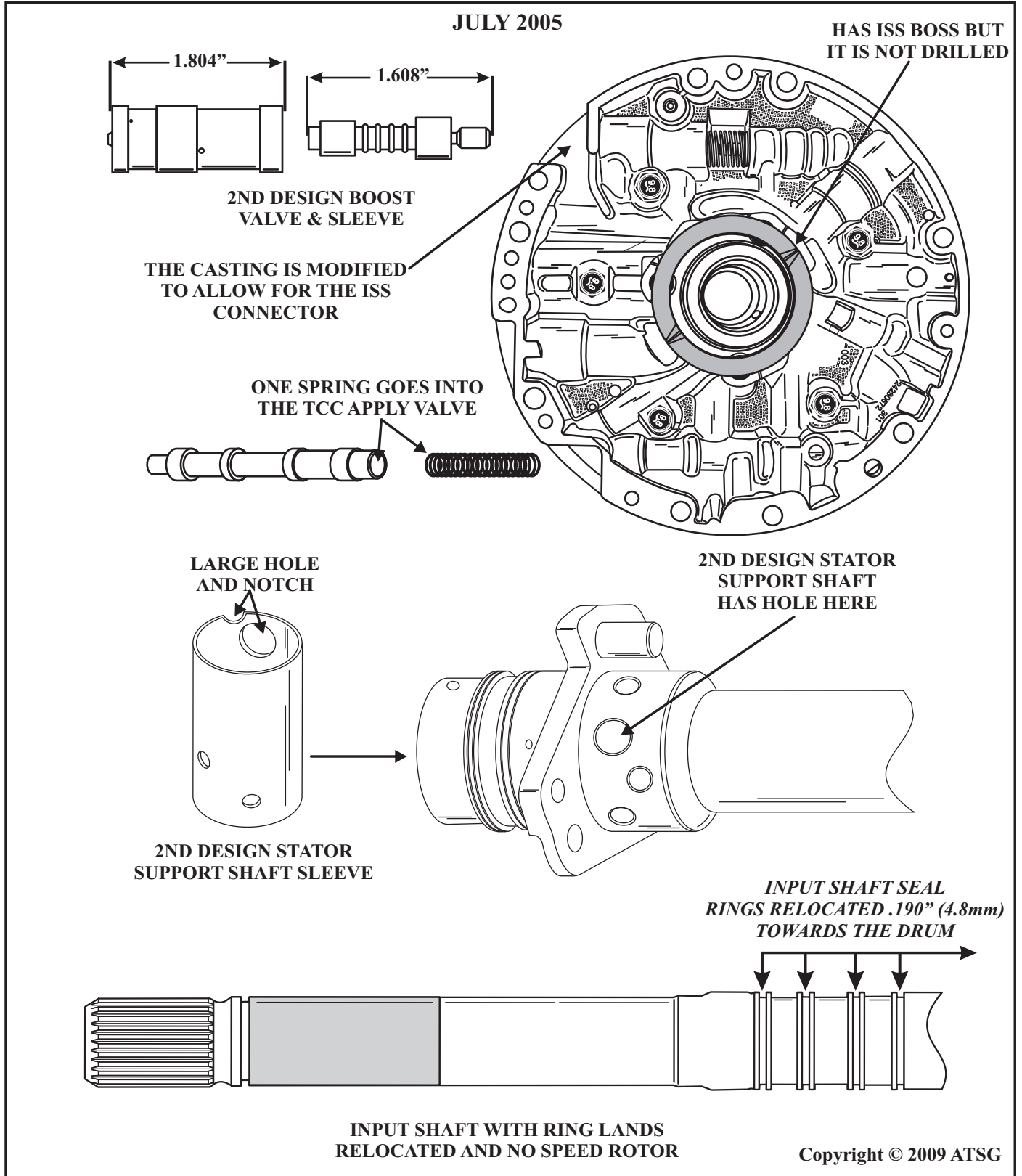

Figure 3